

The background of the advertisement is an aerial photograph of London. On the left, the Shard skyscraper is prominent, its glass facade reflecting the sky. In the foreground, a large, curved, metallic structure, likely a roof or facade, is shown, featuring a complex, ribbed design. The rest of the image shows a dense urban landscape with various buildings, streets, and the River Thames. The sky is a mix of blue and white clouds, suggesting a clear day.

KALZIP® SYSTEMS MADE OF ALUMINIUM
Roof & Facade solutions

FASCINATING
ROOFSCAPES AND
VARIED **FAÇADES**





KALZIP

THE ORIGINAL SINCE 1968

Kalzip is one of the leading suppliers of aluminium building envelopes. We have been producing roof and façade systems using state-of-the-art roll forming machines since 1968. To date, over 110 million square metres of Kalzip profiled sheets have been installed. With international sales offices, and a worldwide fleet of mobile production units, Kalzip is represented in almost every corner of the globe.

Kalzip systems meet the highest requirements in terms of building physics and design, creating roofs and façades with impressive functionality and fascinating appearances.

Building with Kalzip also means taking advantage of our many years of know-how.

For 55 years, Kalzip has been pushing the boundaries of what is creatively feasible, offering sound technical experience and comprehensive planning support for architects and installers.

Discover the innovative and creative possibilities of Kalzip envelopes and be inspired by the versatile, durable system solutions for new builds and renovations.



SLOUGH BUS STATION (UK), Architect: Bblur Architecture

SUSTAINABLE BUILDINGS

WITH POSITIVE LIFE CYCLE BENEFITS

Kalzip is constantly developing sustainable new solutions. Reliability, safety, durability and innovation are the guiding principles in each phase of product development. To be truly considered 'green', buildings should make an active contribution to climate goals.

Buildings are increasingly required to achieve sustainability certifications and quality seals. These certifications evaluate all aspects of sustainable construction – i.e. ecological, economic and socio-cultural. The evaluation criteria also consider technology, processes, application and lifecycle costs.

Kalzip's products have undergone assessment in accordance with BRE, ECO* and FDES - the most important European building certification programmes. They represent a type-III environmental product certification according to ISO 14025 and are recognised and verified by independent examiners.

The development of Intelligent buildings is a growing international construction trend, which aims to deliver high-tech buildings with the highest possible standards of sustainability. Kalzip's sustainable building materials are an obvious choice in these applications.

The future belongs to these so-called 'blue technologies'. Along with the rest of the construction industry, Kalzip strives towards delivering buildings that not only meet international sustainability standards but set new global standards within themselves. Kalzip systems are the perfect choice for attaining this goal.

* European EPD, carried out by the Institution for Building and the environment (IBU e.V).



Institut Bauen und Umwelt e.V.





In Europe, **96%** around of the aluminium which is used in buildings will be collected and recycled.

German Sustainable Building Council, from "The DGNB Certificate"

Aluminium – functional and durable



Kalzip's sustainability credentials come from aluminium itself – an abundant material that can be recycled any number of times. It can provide effective environmental building protection that can last for decades, helping buildings to retain their value. Kalzip products are made, for the most part, from recycled aluminium.

The recycled content of the aluminium coils used in production, both coated and uncoated, lies somewhere between 75% and 95%. This content can vary due to the availability of recyclable aluminium within the market.

Aluminium recycling

■ The 'super (light) metal' of modern construction. It is durable, can be used in a variety of ways and, above all, can be recycled without any loss of quality. It therefore meets the highest ecological and climate-related requirements.

■ Aluminium recycling refers to the re-use of aluminium waste in all forms, although in this context 'aluminium' is a generic term not only for pure aluminium, but also for its many alloys.

■ Aluminium lasts several generations. When aluminium components are dismantled, this material can be recycled and re-used without any loss of quality. Choosing to use aluminium products therefore improves overall construction sustainability and modernisation.

■ If aluminium alloys are collected and recycled in a single variety, the corresponding alloys can be recycled from the resulting melted aluminium without any reduction in quality.

■ The greatest economic and environmental advantage of recycled aluminium is that the recycling process requires less than a tenth of the energy required for primary production of the same amount of aluminium.

ROOF SYSTEMS

- Kalzip Warm roof structures 7
- Kalzip Duo Plus 8
- Kalzip Vented roof Structures 10
- Kalzip Roof refurbishments 12
- Kalzip Solar solutions 13
- Kalzip NatureRoof 14
- Kalzip Roof accessories 15
- Kalzip Profiled sheets 16
- Kalzip Profile forms 17



VIDEOREFERENZ

OAXACA BEACH CAFE (NL), Domburg



NORWICH UNION GLASGOW (UK), Glasgow, Architect: AHR

Kalzip is a flexible, weather-resistant, and easy-to-install building system, with a light-weight construction. Available with extensive system components and accessories, Kalzip can offer a complete solution for building envelopes, which can easily be combined with other building materials. This results in unique buildings that are both visually and technically impressive.

The benefits

- Suitable for all substructures
- Fast assembly that is largely unaffected by weather conditions
- Easily achieve extraordinary building shapes and geometries, thanks to XT freeform profiles
- Fixing-free roof cladding, thus no weak points due to fasteners
- Meets the requirements of Building Regulations
- Durable and sustainable, thanks to the use of recycled aluminium alloy
- No lightning protection is required, as the aluminium standing seam roof serves as a natural arrester. Superstructures of any kind must be checked separately

KALZIP STRUCTURAL DECK ROOF SYSTEM

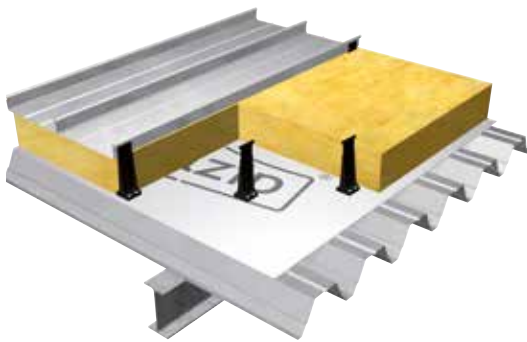

KALZIP DECK ROOF SYSTEM ON PURLINS AND TRAPEZOIDAL STEEL LINER

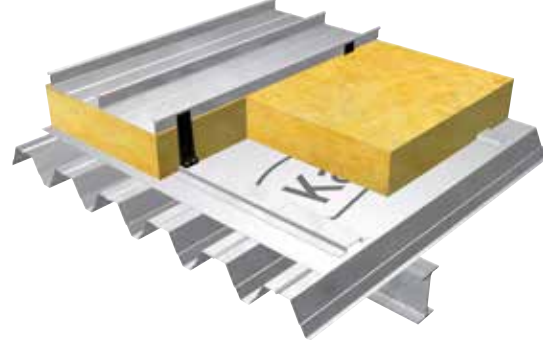

KALZIP ROOF SYSTEM ON TIMBER DECK

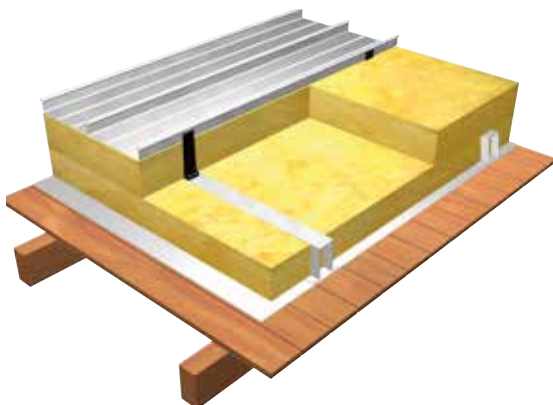

KALZIP ROOF SYSTEM ON CONCRETE DECK

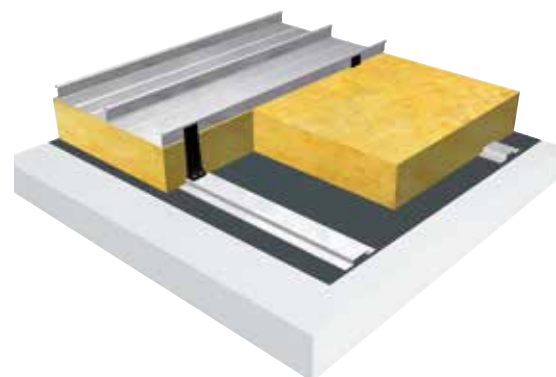

ENERGY SAVING ROOF SYSTEMS

DUO & DUO PLUS

Excellent thermal insulation and sound reduction

- Virtually no thermal bridges – thus low thermal transmittance
- High thermal insulation - always meets the requirements of the current EnEV (Energy Efficiency Ordinance)
- Variable thermal insulation thicknesses
- Suitable for all E clip types and heights
- Excellent sound reduction values up to $R'w = 50$ dB (A), depending on the roof structure
- Lightweight
- Complete system from a single source
- Functional and coordinated system components
- Highly cost-effective and short assembly times due to prefabricated system components
- Suitable for substructures made of steel trapezoidal profiles, concrete, and wood

KALZIP DUOPLUS ON TRAPEZOIDAL STEEL DECK

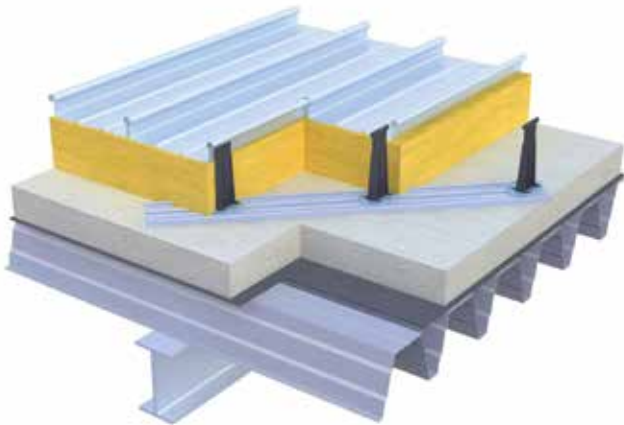

KALZIP DUOPLUS ON TIMBER/PLYWOOD

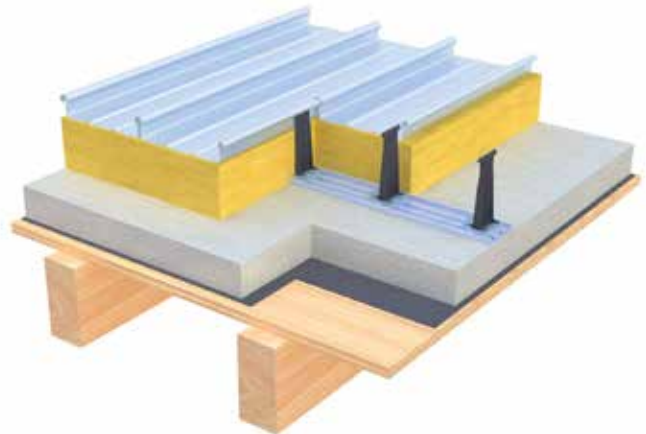

KALZIP DUOPLUS ON CONCRETE SUBSTRUCTURE

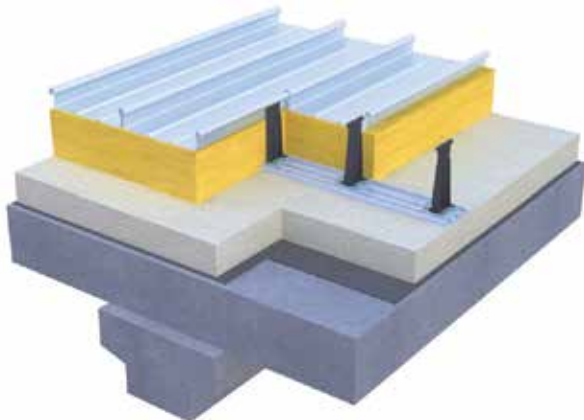

KALZIP DUO ON TRAPEZOIDAL STEEL DECK

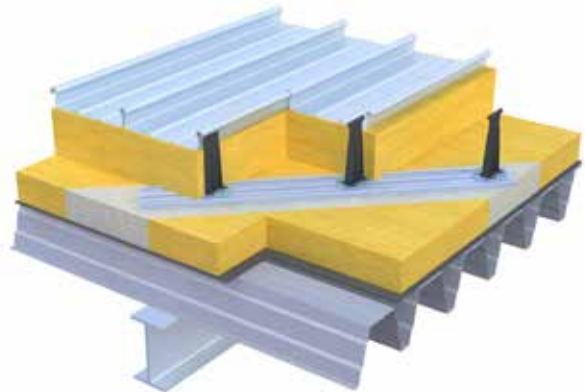



WELSH NATIONAL ASSEMBLY (UK), Cardiff, Architects: Richard Rogers Partnership



Kalzip vented roof structures are cost-effective roof systems that are suitable for both new builds and renovation projects. The rear ventilation offers year-round thermal protection. We have suitable solutions available for all roof structures.

The benefits

- Economical alternative to bitumen roofing membrane and traditional roofing materials, such as tiles or slate
- Low maintenance and no up-keep costs thanks to the durable roof cladding
- Inexpensive overall package thanks to the coordinated system components and finishes
- Better building air quality thanks to ventilation
- Very low weight, even when combined with solar applications

KALZIP - VENTED ROOF STRUCTURE ON FORMWORK

VENTILATED ROOF STRUCTURE ON FORMWORK

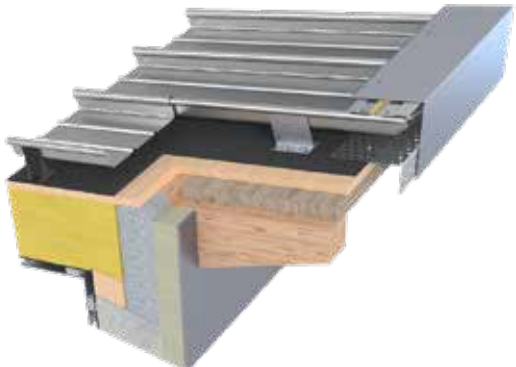
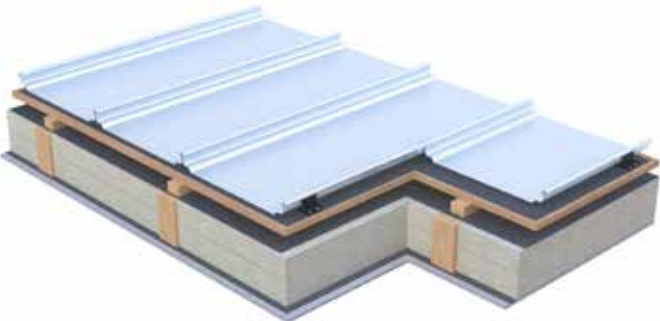

WOODEN ROOF STRUCTURE ON VARIO LB PURLIN 30 (COLD ROOF)

WOODEN ROOF STRUCTURE ON WOODEN PURLINS (COLD ROOF)

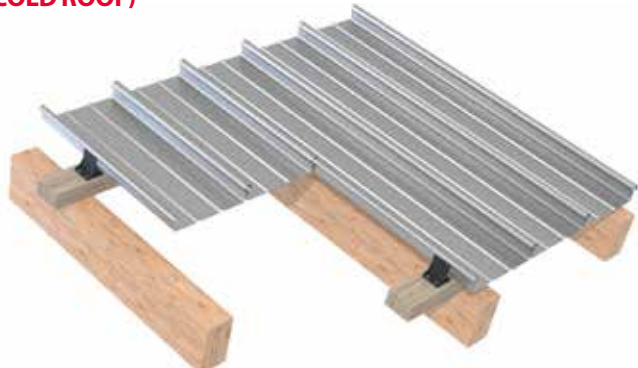

WITH MOBILE
ROLLFORMERS WE CAN
PRODUCE KALZIP AT ANY
PLACE ON EARTH

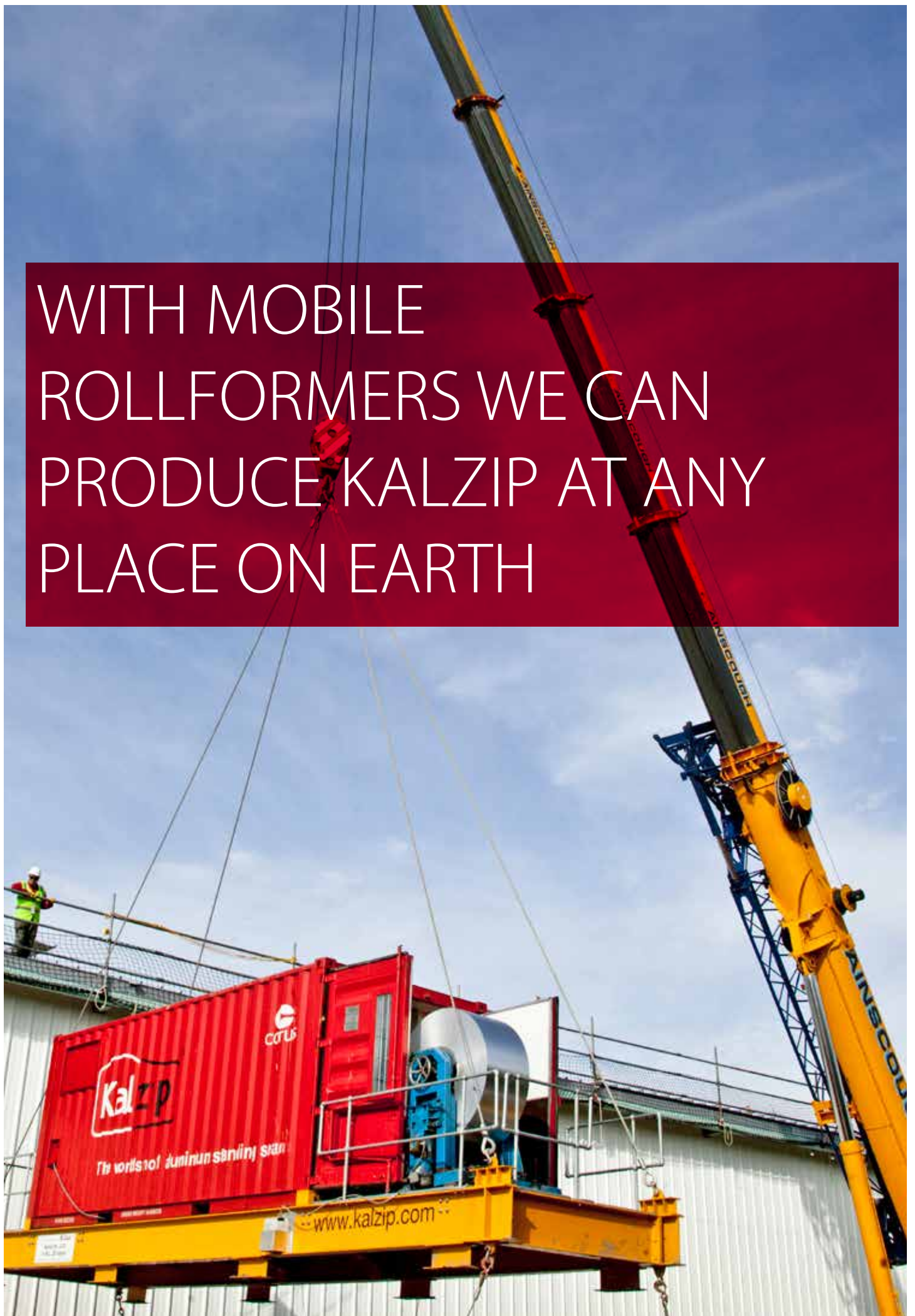



Kalzip renovation solutions stabilise the building structure and, as a result, ensure decades of protection.

As well as meeting thermal insulation requirements, Kalzip's roof systems achieve outstanding noise reduction values. Thanks to their generally low weight, they are also suitable for large spans and old roof renovations.

The benefits

- Maximum corrosion resistance thanks to the use of salt water resistant aluminium
- High design freedom through individual roof shapes
- Buildings can generally remain in use during refurbishment
- In most cases, savings on disposal costs for old roof cladding and insulation layer
- Compliant adaptation to the current EnEV (Energy Efficiency Ordinance)
- Hard durable roofing solution

KALZIP VARIO LB ROOF REFURBISHMENT SYSTEM



KALZIP DUOPLUS FOR COMPOSITE ROOF CONSTRUCTION

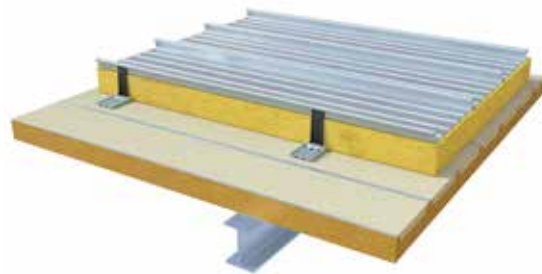

KALZIP REFURBISHMENT OF CORRUGATED ASBESTOS ROOF COVERINGS



KALZIP WARM ROOF - REFURBISHMENT WITH LB PURLIN SHOE

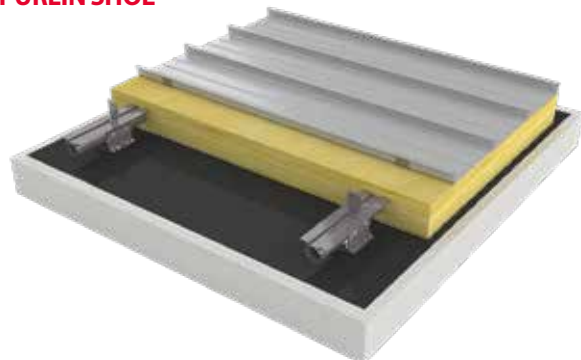



METALINE, Hildrizhausen (D), Architekt: Dälken, Verleger: Zippert GmbH & Co. KG, Produkt: Kalzip AluPlusSolar

Roof-integrated solar modules - Kalzip AluPlusSolar for new buildings and Kalzip® SolarClad for retrofitting into standing seam systems. Both are equipped with a proprietary fibre-reinforced plastic core together with state-of-the-art front, back and EVA films. This guarantees strength, attractive design, flexibility, quality and durability - all in one module.

The benefits

- Maximum design freedom for sophisticated building architecture, thanks to the roof-integrated photovoltaic system without additional fixing elements.
- Retrofitting of existing Kalzip roofs for all widths
- Building authority approved seam clips for maximum safety
- High safety and performance, a fully IEC-certified, glassless, semi-flexible and ultra-light module based on silicon solar cells
- Optimum use of solar energy even in poor light conditions, thanks to the microlens-shaped surface composed of ETFE (ethylene tetrafluoroethylene) film

KALZIP ALUPLUSOLAR

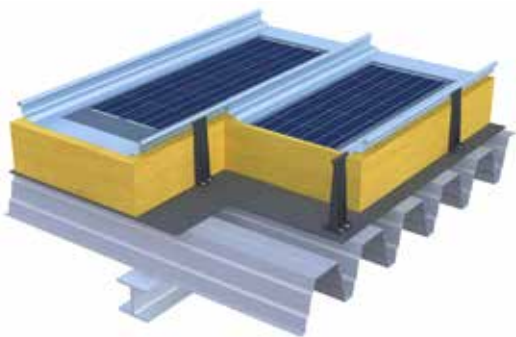

KALZIP SOLARCLAD (IDEAL FOR RETROFITTING)



KALZIP VARIO LB + ALUPLUSOLAR

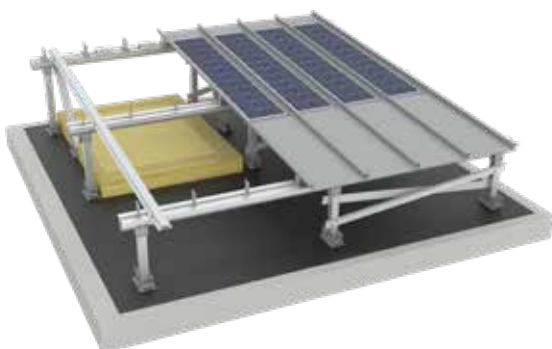

KALZIP SEAM CLAMP FA PV

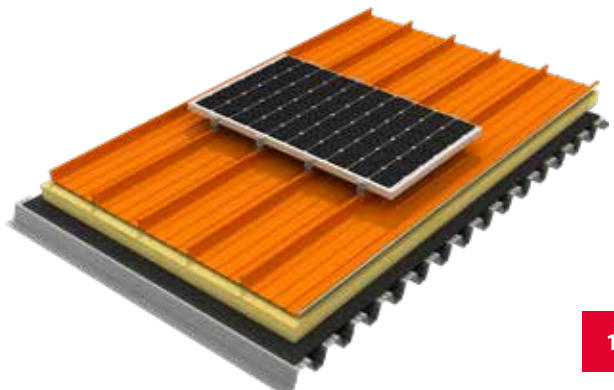



NATUREROOF

The components of the Kalzip NatureRoof structure are delivered to the construction site as separate units. The functional layers work together to form a complete system when installed.

The benefits

- Construction without additional sealing measures directly on the Kalzip profiled sheets
- Highly cost-effective and fast assembly
- Environmentally friendly
- Improves the thermal protection and indoor climate of the building throughout the year.
- Improvement of micro-climate
- Slows water drainage
- Minimal maintenance

ROOF CONSTRUCTION KALZIP NATUREROOF

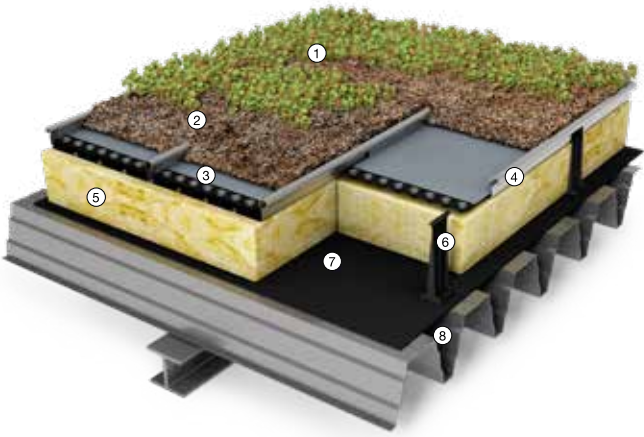

- ① Kalzip Sedum planting
- ② Kalzip Planting substrate
- ③ Kalzip Drainage mat with filter fleece sheathing
- ④ Kalzip Profiled sheets (Kalzip 65/400 or Kalzip 65/333),
- ⑤ Kalzip Insulation
- ⑥ Kalzip advanced E type clip
- ⑦ Kalzip Vapour control layer
- ⑧ Structural deck on rafters

ROOF ACCESSORIES

Precisely matched system components and useful accessories complement Kalzip's variety of design options. Technical requirements are given the highest priority, for a long service life, easy handling, safe assembly and material recyclability.

Intelligently designed and technically advanced solutions for a complete roof structure:

- Steel or aluminium support shell
- Kalzip vapour barriers
- Insulating materials (compressible or high density if required)
- Kalzip system E-clips
- System fasteners for all substrates
- Roof path systems with and without railings, adaptable to respective roof geometries
- Latchways CFP – building authority approved rope-guided fall protection system for Kalzip® standing seam roofs
- Kalzip snow guard system
- Kalzip seam clips for the penetration-free fastening of additive systems
- Lightning protection components
- and much more

FALL ARREST SYSTEM LATCHWAYS CFP



KALZIP ROOF WALKWAY SYSTEM



KALZIP SEAM CLIPS



KALZIP SNOW GUARD SYSTEM



PROFILE WIDTHS

STANDARD PROFILES

Kalzip 50/429

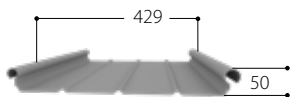

Kalzip 65/400

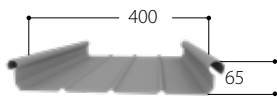

Kalzip AF 65/434

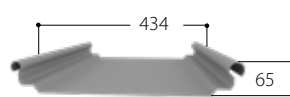

Kalzip AS 65/422

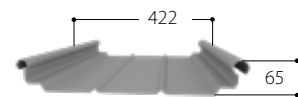

Material thicknesses

0.8 / 0.9 / 1.0 and 1.2 mm depending on quantities and surfaces

*AluPlusPatina natural stucco-embossed, mf Basic & EQ only in 1.0 mm

STANDARD PROFILES

Kalzip 65/500

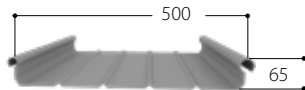

Kalzip AF 65/537



Kalzip 50/444

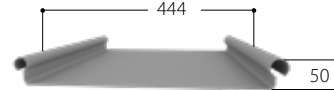

Material thicknesses

Kalzip 65/500 and WF 65/537:

- 0.8 und 1.0 mm in stucco-embossed
- 0.8 mm and AluPlusPatina Natural-Aluminium mf Basic
- 0.9 / 1.2 mm depending on quantities and surfaces
- WF profile in combination with PV only in 1.0 mm thickness

Kalzip 50/444:

- only 1.0 mm

NON STANDARD PROFILES (on request, depending on minimum quantity, Aluminium core material: According to approval Z-14.1-181)

Kalzip 50/333

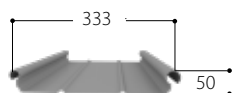

Kalzip 65/305

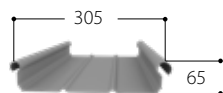

Kalzip 65/333

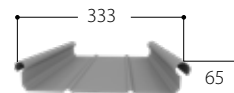

Kalzip AF 65/333

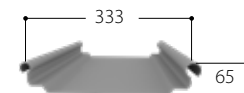



1) Straight profile sheet



2) Convex curved profile sheet



3) Tapered convex curved profile sheet



4) Tapered profile sheet



5) Tapered concave curved profile sheet



6) Concave curved profile sheet



7) Example XT freeform profiled sheet

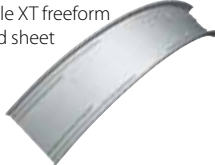

8) Example XT freeform profiled sheet

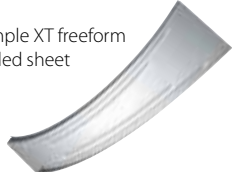

9) Example XT-Freeform



KALZIP STANDS FOR **SUSTAINABLE AND DURABLE** ROOF & FAÇADE SYSTEMS!



ATELIER HAMES REMIXX, Rumelange (LU), Architect: 2001, Installer: Prefalux SA, Product: Kalzip 50/429 in Stucco embossed

FAÇADES SYSTEMS

Kalzip FC Façade system	20
Kalzip TF 37/800 R Façade system	21
Kalzip Standing seam façade	22
Kalzip perforated façades	24





IVY STATION (US), Culver City, CA

The patented Kalzip FC façade system is a suspended, rear-ventilated metal facade. It sets new standards in terms of flexibility, ease of assembly and cost-effectiveness. The Kalzip FC façade system offers architects and planners a variable and easy-to-assemble building product for new builds and renovation projects.

The benefits

- Fast, safe and simple installation thanks to the patented click system.
- Can be installed from top-down or bottom-up
- Planning support for substructure and FC façade
- Durable, sustainable and very affordable façade solution
- Sustainable product with product-specific declaration (EPD) according to DGNB
- Simple replacement for damaged façade panels

FC FACADE SYSTEM ON MASSIV WALL WITH MODULAR CLICK RAIL SEL



FC FACADE SYSTEM ON STEEL CHASSETTE



FC FACADE SYSTEM ON MASSIV WALL WITH MODULAR CLICK RAIL SE

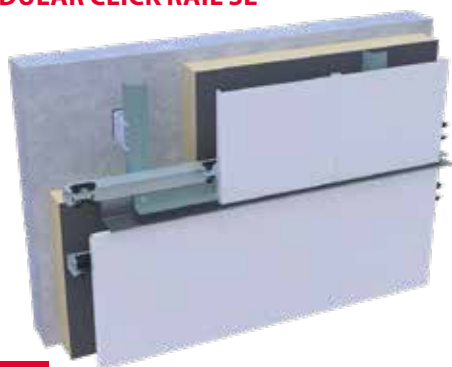

FC FACADE SYSTEM ON SANDWICH PANELS

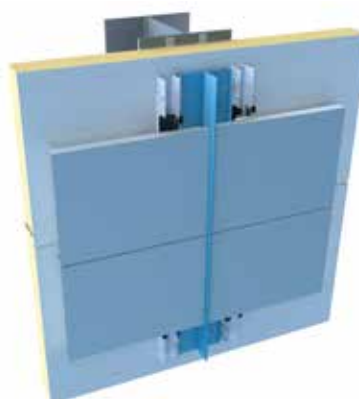



TF 37/800 R FAÇADE

FIRE DEPARTMENT NO. 5, Levis (CA), Architect: STGM - St-Gelais Montminy + Associés, Product: Kalzip TF 37/800 R in AluPlusPatina UltraDark

Kalzip façade panels offer architects and builders an opportunity to create bespoke tailor-made designs. Through efficient production as well as economical and thus ecological use of material they meet all the requirements for practical construction

The benefits

- Unmistakable aesthetic design
- Cost-effective
- Lightweight
- Various options for acoustic and thermal insulation

- Micro-rib
- Impact-resistant façade

CONCRETE AND MASONRY SUBSTRUCTURES

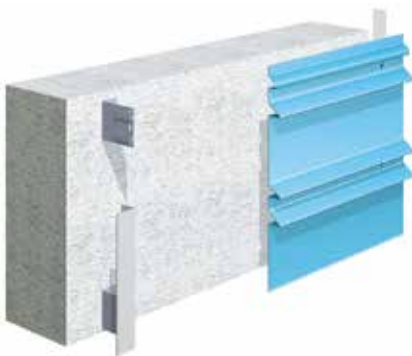

TRAPEZOIDAL SUBSTRUCTURES



TRANSOM/ MULLION CONSTRUCTIONS SUBSTRUCTURES



INTERMEDIATE STRUCTURES FOR CASSETTES





Kalzip standing seam façades offer sustainable and cost-effective weather protection and, thanks to their versatility, are the perfect design solution for creating unique building aesthetics. The seams can be installed vertically or horizontally, which will determine the final appearance. In addition, a variety of finishes and colours are available to the designer.

The benefits

- High-quality sophisticated metallic or coated surfaces constructed from durable aluminium
- Solar shading applied to front of glass façades
- Differentiation between public and semi-public space
- Ideal for the improving the appearance of unsightly existing facades
- Highly corrosion-resistant for long-term building protection
- Cost-effective renovation of façades

STRUCTURE KALZIP STANDING SEAM FAÇADE







PERFORATED FAÇADE

GERMAN AIR CONTROL, Kaufbeuren (GER), Architect: HENN Architekten, Product: Kalzip 65/400 + RV 6/8

PERFORATED KALZIP PROFILE SHEETS

straight



Convex curved



Concave curved



PERFORATED KALZIP FC FAÇADE PANELS



RV 6-8
Perforation percentage:
min. 44 %, max. 48 %
depending on panel width
Perforation diameter: 6 mm



RV 3-5
Perforation percentage:
min. 29 %, max. 31 %
depending on panel width
Perforation diameter: 3 mm

PERFORATED KALZIP TF 37/800 R FAÇADE PANELS



FOLDABLE ALUMINIUM



HÖLDERLIN HAUS (GER), Nürtingen, Architect: Aldinger Architekten

FOLDABLE ALUMINIUM

BODEGAS BERONIA (ES), La Rioja, Architect: IDOM Architects, Installateur: CYAR, Produkt

Kalzip foldable aluminum is the ideal material for installation using traditional folding techniques. Almost any shape can be implemented for roofs and facades. Can easily be folder, profiled and flanged using proven and established techniques' instead of.

The advantages for designers and installers:

- Design freedom due to virtually unlimited formability
- Impressive price-performance ratio
- Certainty regarding planning, construction time and costs due to simple processing of the material, even at low temperatures without pre-heating
- Highly corrosion-resistant for long-term building protection
- Easy to process using traditional roofing techniques
- A 100 kg roll of FalZinc with a cover width of 600 mm has an unrolled length of about 88 metres in comparison to 33 metres in the case of zinc
- A solid timber separating layer is unnecessary in most structures

DOUBLE STANDING SEAM



ANGLED STANDING SEAM



DOUBLE-SHELL, REAR-VENTILATED ROOF STRUCTURE

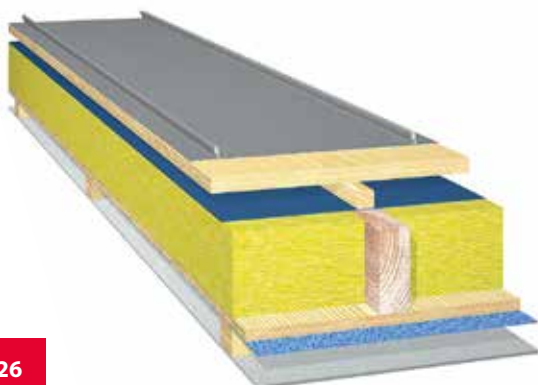

DOUBLE-SHELL, REAR-VENTILATED FAÇADE STRUCTURE







WWW.KALZIP.COM

Kalzip is a registered trademark. The greatest possible care has been taken to ensure that the contents of this publication are correct. However, neither Kalzip nor its trade representatives can accept any responsibility or liability for errors or for information that may be construed as misleading.

It is the customer's duty to check the suitability of the products manufactured or supplied by Kalzip GmbH before using them.

Copyright ©2024
Kalzip GmbH



Kalzip GmbH
August-Horch-Str. 20 – 22
56070 Koblenz
Germany

+49 (0) 261 9834-0
mail@kalzip.com